

DIPLOMA EXAMINATION IN ENGINEERING/TECHNOLOGY/
MANAGEMENT/COMMERCIAL PRACTICE — OCTOBER, 2017

THEORY OF STRUCTURES - I

[Time : 3 hours

(Maximum marks : 100)

PART — A

(Maximum marks : 10)

Marks

I Answer *all* questions in one or two sentences. Each question carries 2 marks.

1. List the characteristics of a force.
2. Define radius of gyration.
3. State Poisson's ratio.
4. Define the term torque.
5. State moment of resistance.

(5 × 2 = 10)

PART — B

(Maximum marks : 30)

II Answer any *five* of the following questions. Each question carries 6 marks.

1. Calculate the support reactions of a simply supported beam of 4m span with a Point Load of 10kN at its Centre of span and a u.d.l of 2kN/m thought its span.
2. Determine the Centre of Gravity of the solid body consists of right circular cone placed on a solid hemisphere as shown in figure from C.

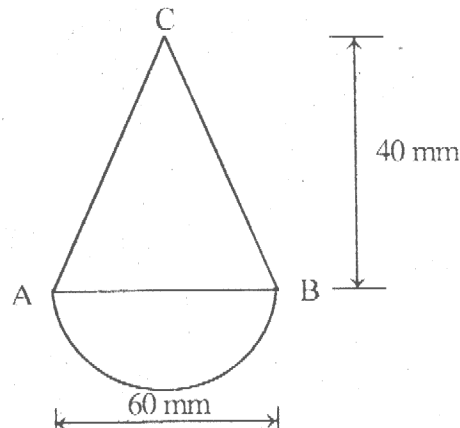

3. An alloy bar 1m long and 200mm^2 in cross section area is subjected to a compressive force of 20kN. If the modulus of elasticity for the alloy is 100GPa, find the decrease in length of the bar.
4. Define the terms :
 - (i) Volumetric strain
 - (ii) Bulk modulus
 - (iii) Modulus of rigidity.
5. Determine the maximum shear stress developed, if the average torque transmitted by a shaft is 2255Nm. The maximum torque is 40% more than the average torque and the diameter of the shaft is 80mm.
6. Differentiate longitudinal stress and hoop stress in thin cylinders.
7. List the assumptions in the theory of simple bending. (5 × 6 = 30)

PART — C

(Maximum marks : 60)

(Answer *one* full question from each Unit. Each full question carries 15 marks.)

UNIT — I

- III (a) Calculate the moment of inertia of the 'L' section shown in figure about a vertical axis passing through its centre of gravity.

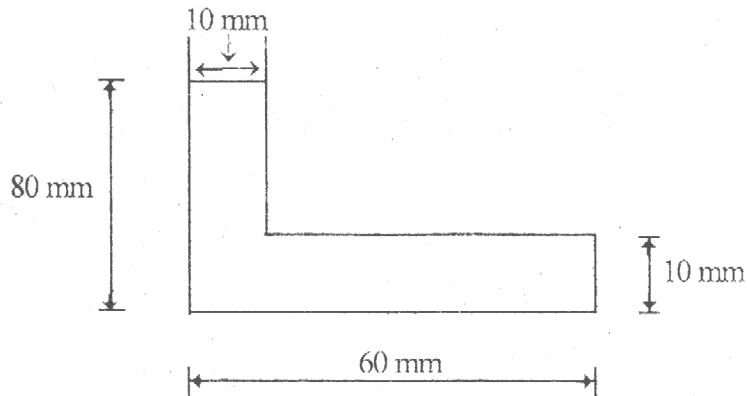

8

- (b) Determine the centroid of the lamina shown in figure from AB

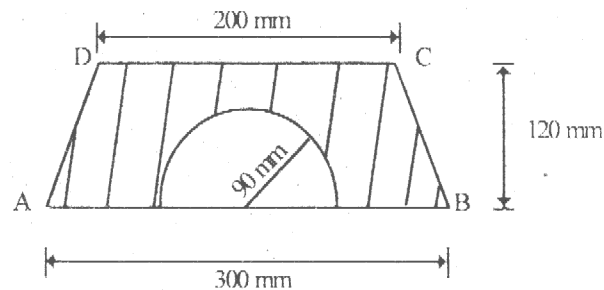

7

OR

- IV (a) Calculate the support reactions of a simply supported beam AB of span 4m with a uniformly varying load of 2kN/m at right support B to 8kN/m at the left support A. 8
- (b) Determine the polar moment of inertia of a rectangular section of 200mm width and 300mm depth. 7

UNIT — II

- V (a) Define the terms :
 (i) Elasticity (ii) Hardness (iii) Ductility (iv) Stiffness. 8
- (b) A brass rod 2m long is fixed at its two ends. If the thermal stress is not to exceed 76.5MPa, calculate the temperature through which the rod can be heated. Take $\alpha = 17 \times 10^{-6}/^{\circ}\text{C}$ and $E = 90\text{GPa}$. 7

OR

- VI (a) A metal bar 50mm \times 50mm section is subjected to an axial compressive load of 500kN. The contraction for a 200mm gauge length is found to be 0.5mm and increase in thickness is 0.04mm. Find the values of young's modulus and Poisson's ratio. 8
- (b) A metallic bar of 500mm \times 200mm and 2m long is subjected to a load of 150kN applied gradually on it. If the stress at elastic limit of the bar material is 200N/mm², determine
 (i) Strain energy
 (ii) Proof resilience
 (iii) Modulus of resilience $E = 200 \text{ kN/mm}^2$. 7

UNIT — III

- VII (a) Sketch SFD and BMD for an overhanging beam shown in figure and calculate the maximum bending moment. 8

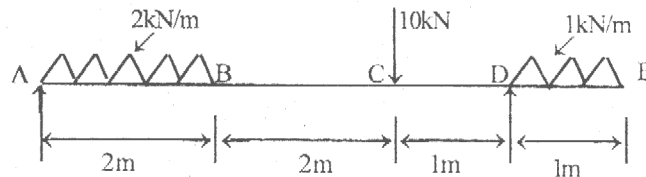

- (b) Calculate the maximum torque that can be safely applied to a shaft of 80mm diameter. The permissible angle of twist is 1.5 degree for a length of 5m and shear stress not to exceed 42MPa. Take $N = 84\text{GPa}$. 7

OR

- VIII (a) Sketch SFD and BMD of a cantilever beam shown in figure. 8

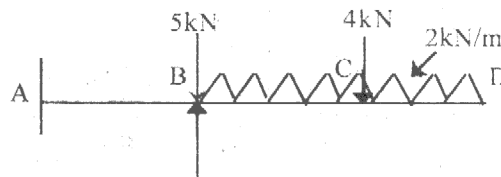

- (b) A spherical shell of 2m diameter is made up of 10mm thick plates. Calculate the change in diameter and volume of the shell, when it is subjected to an internal pressure of 1.6MPa. Take $E = 200\text{GPa}$ and $1/m = 0.3$. 7

UNIT --- IV

- IX (a) A beam of $200\text{mm} \times 400\text{mm}$ in cross section is simply supported at the two ends. It carries a u.d.l of 10kN/m over the entire span. Find the maximum permitted span, if the maximum bending stress permitted is 50N/mm^2 . 8
- (b) Derive a formula for shear stress at the section of a loaded beam. 7

OR

- X (a) Derive the equation for simple bending. 8
- (b) Calculate the maximum shear stress at the section of a simply supported beam of rectangular Section of size $200\text{mm} \times 300\text{mm}$, if the shear force at the section is 100kN . Also calculate the Shear stress at a point 50mm above Neutral axis. 7
-