

**DIPLOMA EXAMINATION IN ENGINEERING/TECHNOLOGY/MANAGEMENT/
COMMERCIAL PRACTICE – APRIL 2018**

MACHINE DRAWING

[Maximum Marks: 100]

[Time: 3 Hours]

- [Note:-1. All dimensions are in mm.
2. First angle projections is to be followed.
3. Missing data if any may be suitably assumed.
4. Both sides of the drawing sheet may be used.
5. Sketches accompanied.]

UNIT - I

- I. Draw the three views of a hexagonal nut suitable for M 30 bolt. Enter all dimensions in terms of bolt diameter. (15)
- OR
- II. Draw the sectional elevation and plan of double riveted lap joint (zig zag type) for joining plates of thickness 12 mm. Insert all dimensions in terms of diameter. (15)

UNIT - II

- III. Draw the full section elevation and end view of a Gib and cotter joint shown in figure I. (30)
- OR
- IV. Isometric view of a flanged coupling (protected type) is shown in figure 2. Draw the full sectional elevation and end view. (30)

UNIT - III

- V. Detailed views of a Plummer block is shown in figure 3. Assemble the parts and draw the left half sectional elevation and plan. (40)
- OR
- VI. Detailed views of a stuffing box is shown in figure 4. Assemble the parts and draw full sectional elevation and plan. (40)

UNIT - IV

- VII. Draw the welding symbols of the following
- Square butt weld
 - Fillet weld

- c) Plug weld
- d) Spot weld
- e) Seam weld

(15)

OR

VIII. Draw the double line orthographic symbol of the following pipe fittings.

- a) 90° Elbow
- b) Cross
- c) Bend
- d) Reducer
- e) Union

(15)

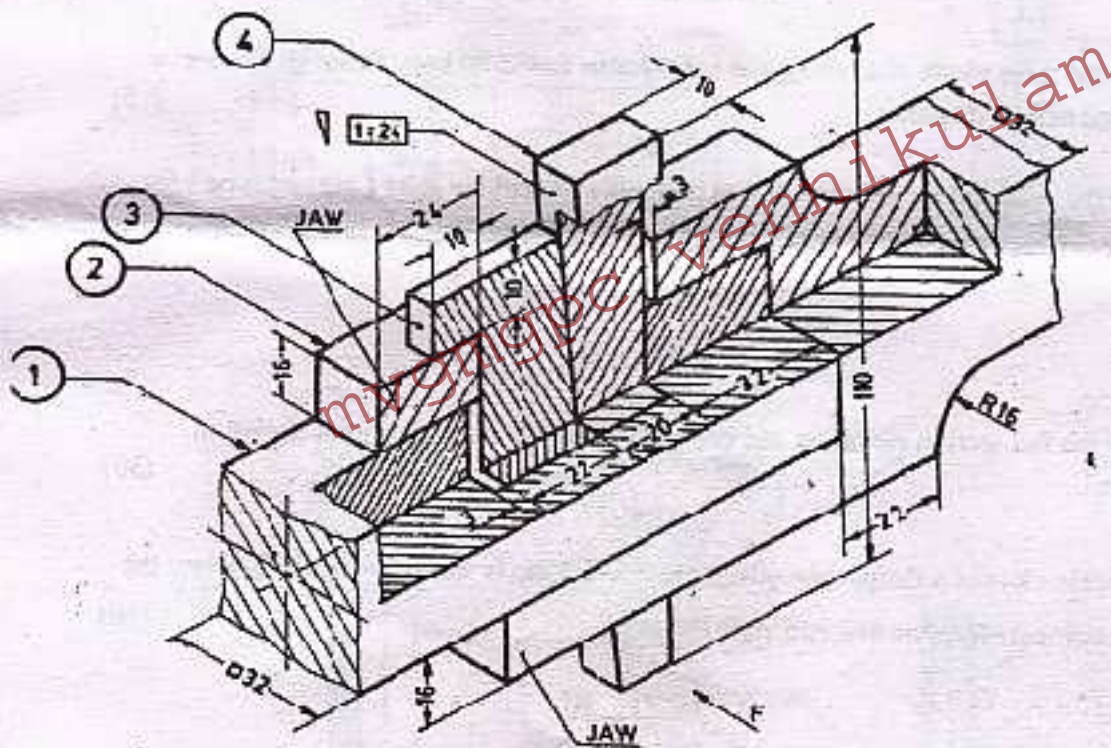

Figure 1

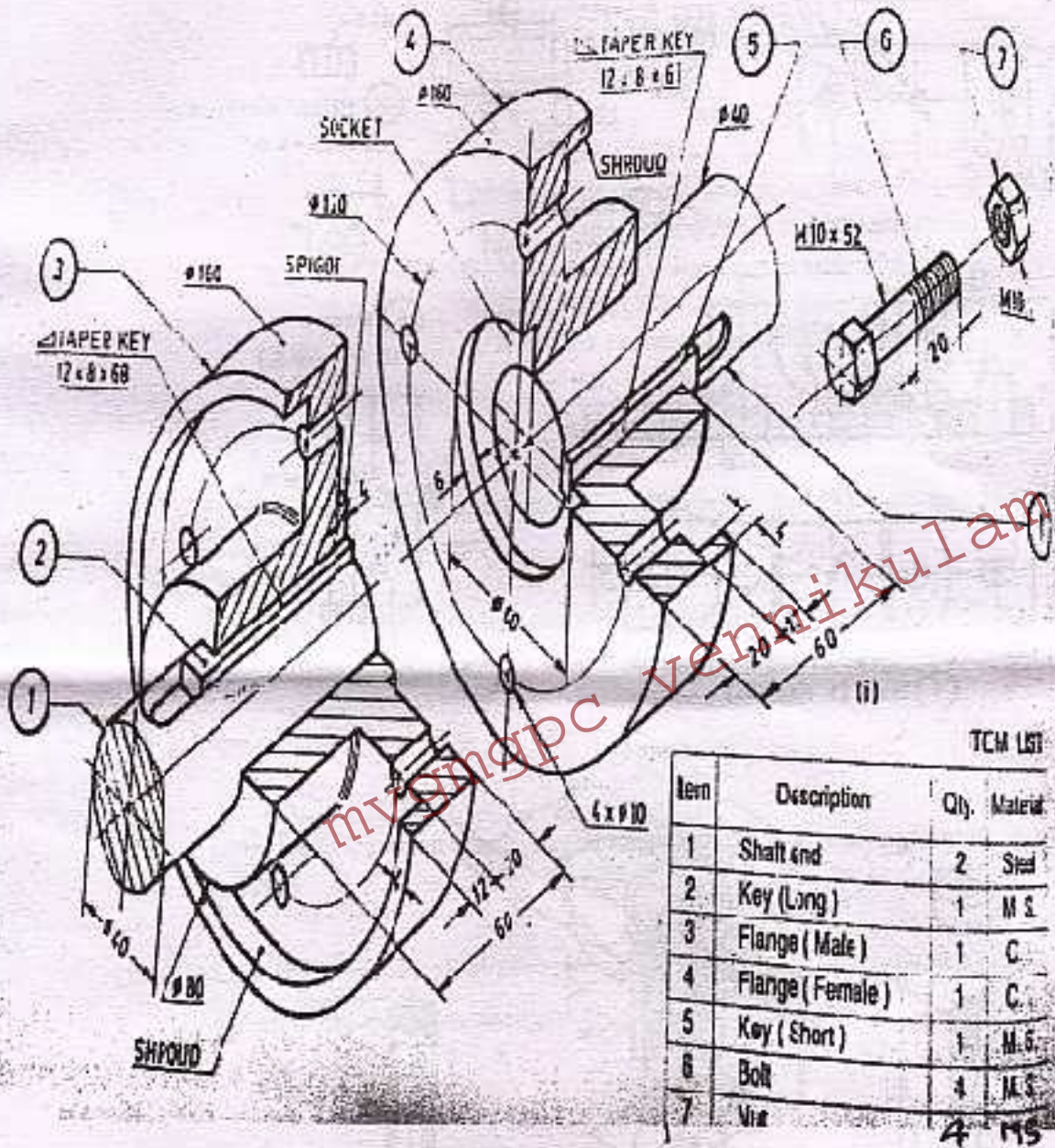

Figure 2

Figure 3

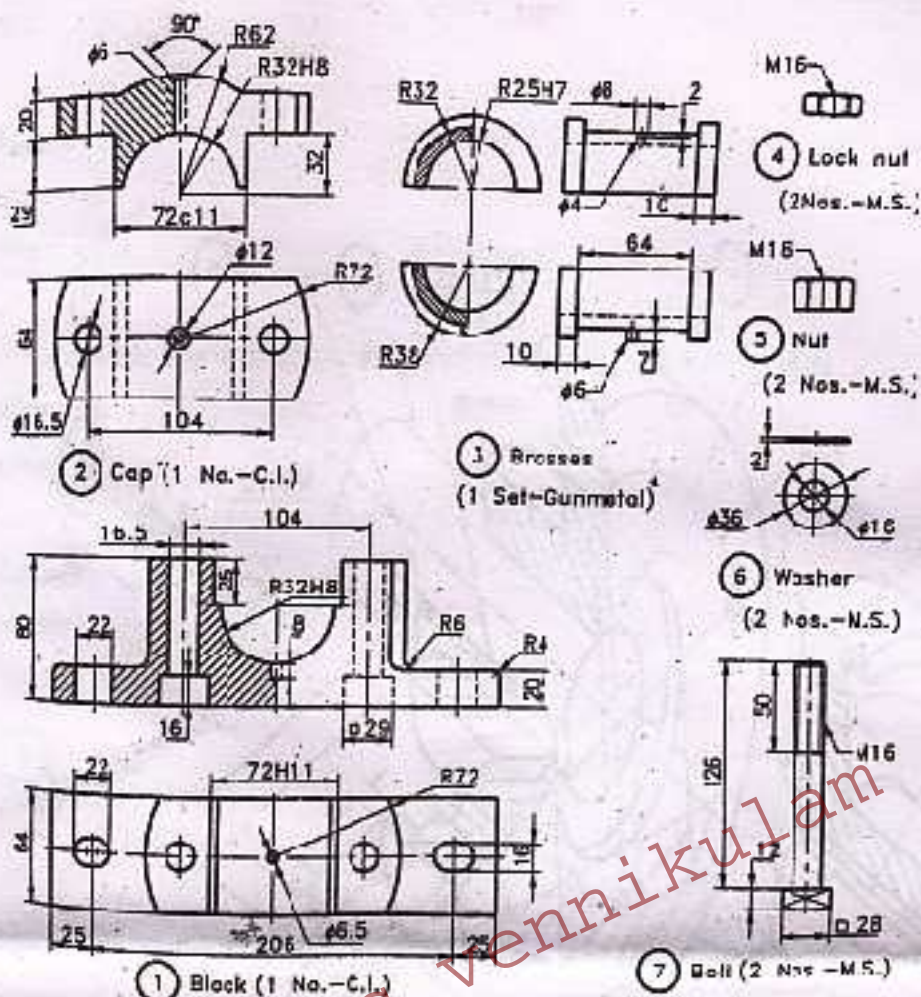

Figure 4

